

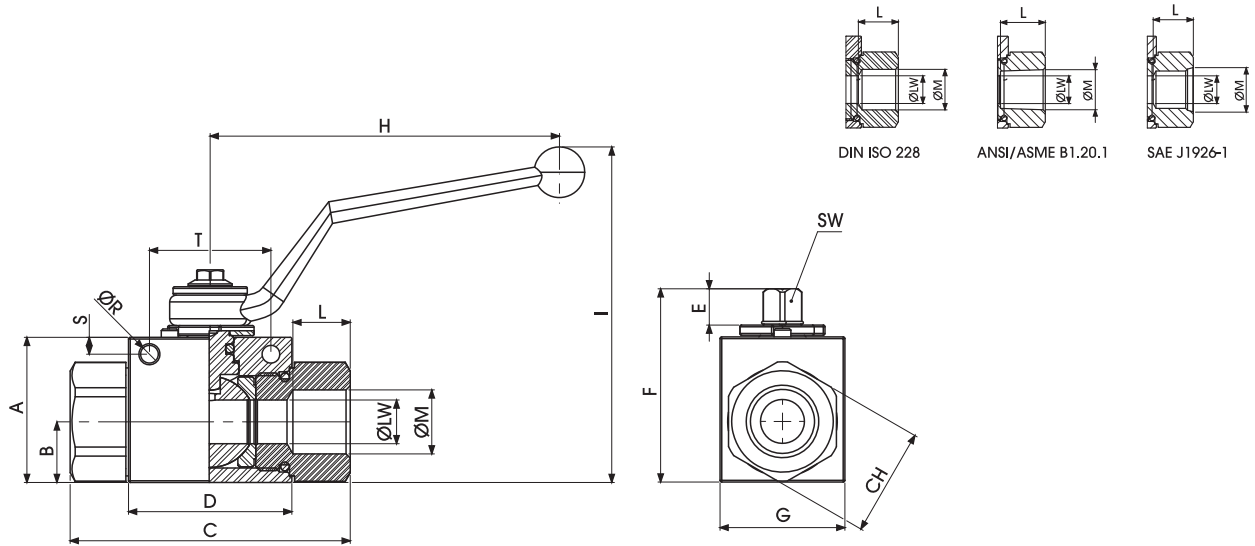

2-WAY HIGH PRESSURE BALL VALVES



DIN/ISO 228 BSP

Fixing holes

CARBON STEEL

CODE	PN	DN	A	B	C	D	E	F	G	H	I	L	ØM	CH	ØR	S	T	SW	ØLW	KG
22.02.04	50 Mpa	6	33	14.3	69	39.4	10.8	47.30	26	111	90	14.8	G1/4	22	5.25	4.5	33	9	6	0.378
22.02.06	50 Mpa	10	35	15.0	71	41.8	10.8	49.30	30	111	92	14.6	G3/8	27	5.25	4.5	33	9	10	0.467
22.02.08	50 Mpa	13	40	18.3	83	44.4	10.8	54.30	35	111	97	19.3	G1/2	30	5.25	4.5	33	9	13	0.635
22.02.12	40 Mpa	20	57	23.4	95	62.5	14	73.5	49	180	106.5	21	G3/4	41	6.25	6	50	14	20	1.438
22.02.16	35 Mpa	25	65	29.5	112	66.5	14	83.50	55	180	116.5	24	G 1"	50	6.25	6	50	14	25	2.223
22.02.20	35 Mpa	25	65	29.5	120	66.5	14	83.50	55	180	116.5	24	G 1.1/4"	55	6.25	6	50	14	25	2.273
22.02.24	35 Mpa	25	65	29.5	124	66.5	14	83.50	55	180	116.5	24	G 1.1/2"	60	6.25	6	50	14	25	2.286