

DESCRIPTION

Solenoid valve 2 way normally closed with servo-assisted diaphragm

CONSTRUCTION

Body and cover	Brass
Armature tube	AISI 303
Plunger and core	AISI 430FR
Springs	AISI 302
Seal material	NBR - FPM - EPDM



FEATURES

- Minimum differential pressure 0.15÷3bar
- Maximum allowable pressure PS 20bar^④
- Maximum fluid viscosity 25cSt (mm²/s)
- Ambient temperature: from -10°C to +80°C according to the coil
- Preferred mounting position with vertical coil above

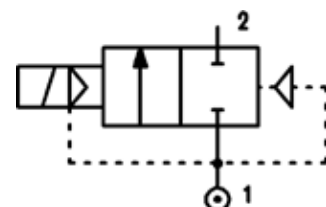

- OPTIONS:**
- Manual override
 - Electroless nickel plating
 - Version for vacuum applications (air/gas)
 - us certified coils

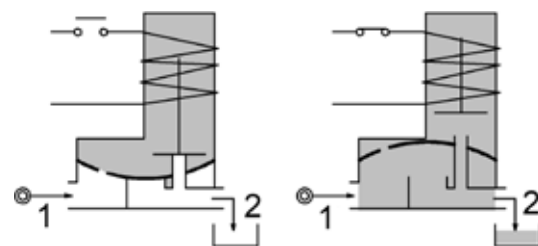

CODE ① ②	Connection G ISO 228	Orifice mm	Kv m ³ /h	Differential pressure bar			Nominal power			Coil		Seal ①	Temp. range °C
				Min	Max		AC Inrush	VA Holding	DC Watt	Series	Width		
					AC	DC							
E107G...37///...	1"1/4	37	18	0.15	10	10	20	15	10	2	30	NBR=B EPDM=E FPM=V	-10 +90 -10 +140 -10 +140
E107H...37///...	1"1/2	37	21	0.15	10	10							
E107I...50///...	2"	50	36	0.15	10	10							
E107MB75///...	2"1/2	75	75	0.3	5	5	20	15	10	2	30	NBR=B	-10 +90
E107RB75///...	3"	75	84	0.3	5	5							
③E107MB75/W/...	2"1/2	75	75	3	15	15							
③E107RB75/W/...	3"	75	84	3	15	15							

- ① Seal
 - ② Coil
 - ③ Reinforced diaphragm
- Example: E107IB50///201 NBR seal
Coil 24V DC

④ REMARK

The maximum allowable pressure PS for steam 2,5bar (gauge pressure)

G2"1/2 e G3" SOLENOID VALVES

For applications with fluids listed in chapter 3 / group 1 of the PED Directive 2014/68 / EU (potentially hazardous or explosive fluids / mixtures) consider a PS value reduced to 15 bar max.

COILS	Alternating Current 50/60Hz (V)							Direct Current (V)			Electrical connection	Connectors
	12	24	48	110	220 230	240	380	12	24	48		
Series 2 Width 30 Code ②	20A	20B	20C	20D	20E	20F	20G	200	201	202	DIN 43650A	PG9 code 10349000

DESCRIPTION
 Class F insulation
 Voltage tolerance
 AC +15% -10%
 DC ± 10%
 Protection class
 IP65 with connector fitted
 IP60 without connector
 Continuous service ED100%

OPTIONS
 Class H insulation
 Cable attached
 Special coil voltage
 Special coil powers
 CE certified coils

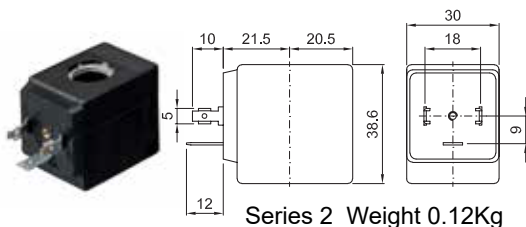

(for more details see section 8)

SPARE PARTS LIST

1. Coil fixing nut
2. Coil
3. Plunger
4. Armature tube with core
5. Diaphragm assembly
6. Speed control valve
7. Water hammering reducer
 $\varnothing 0.8$ - $\varnothing 1.2$ - $\varnothing 1.5$ (G2"1/2-3")

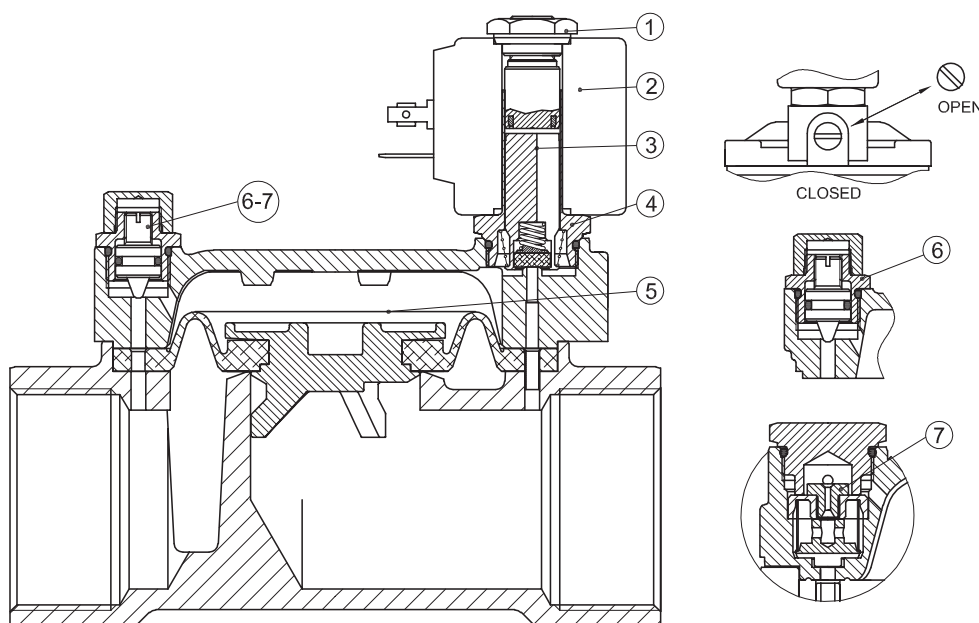

OVERALL DIMENSION

CONNECTION	a	b	c	d	e	f	weight Kg
G1"1/4	142	105	28	102	21	30	3.00
G1"1/2	142	105	28	102	21	30	2.85
G2"	158	115	35	119	21	30	4.30
G2"1/2	226	134	51	169	21	30	11.7
G3"	226	134	51	169	21	30	9.9