



# HP series

## HP

**Air-hydraulic pump, single acting, pedal operated, oil flow (l / min):**  
 0,8 / 0,1-1000bar - 0,8 / 0,2-700bar - 1,4 / 0,8-500bar - 2,4 / 0,5-350bar  
 - 2.1 / 0.6-250bar

### Series: HP

Product line: Industrial tools, lifting systems, car repairers, clamping systems, hydraulic equipment (presses, jacks, ...), tire changers, Automotive

- Operated through pedal
- Unmistakable pedal design with handle for portability
- 3-position pedal operation with spring return (advance, hold and return)
- Single-acting cylinder compatibility (double-acting with optional in-line distributor)
- Compact and sturdy construction for heavy duty and long life
- Easy maintenance
- No air lubricated required
- Connectable to the normal pneumatic network
- Versatile use in both horizontal and vertical positions
- Helical vent screw on the lid for tank ventilation during use
- Preset safety valve on the cover against any overload in the pump
- Externally adjustable oil pressure relief valve against any overload
- Rotating oil port for easy connection to the hydraulic system and improved mobility
- Slots on the base support for easy installation and fixing to the system
- Lightweight
- Low noise (80dBa)
- 1.4 L tank capacity for small and large cylinders (other versions available SL 2.5l and XL 4L)

### Technical features and Series comparison:

Max working pressure (bar):	250	350	500	700	1000
Cylinder compatibility:	Single effect Double effect through in line hand valve (optional)				
Oil tank capacity (L):	1,4 - 2,5 - 4				
Usable oil (L):	1,1 - 2,15 - 3,5				
Max flow rate at nominal pressure (l / min):	0,6	0,5	0,8	0,2	0,1
Oil flow without load (l / min):	2,1	2,4	1,4	0,8	0,8
Oil flow with load (l / min):	0,6	0,5	0,8	0,2	0,1
Oil port:	3/8"NPTF (G3/8" - G1/4")				
Air port:	G1/4"				
Valve function:	Advance / hold / release				
Valve operation:	Manual				
Energy source:	Air				
Pneumatic range (bar):	5/8-10max				
Average air consumption (l / min):	345		300	330	400
Noise (dBA):	80				
Weight (Kg):	5,3				

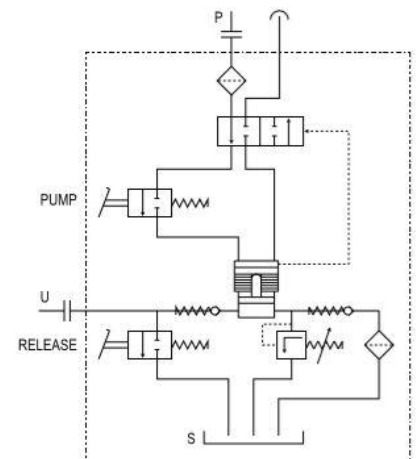

Size:

HP 1,4 L

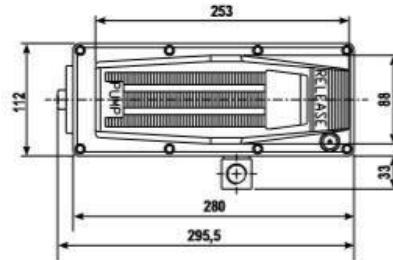
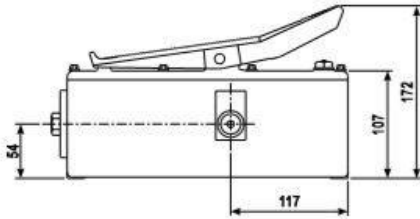

HP-SL 2,5 L

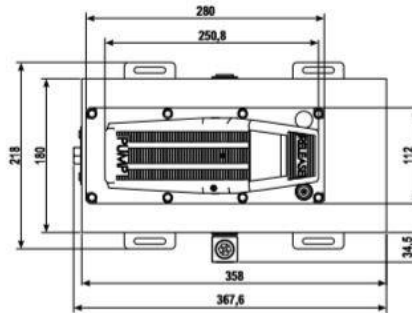
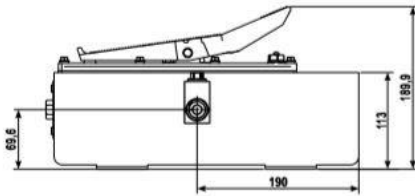

HP-XL 4 L

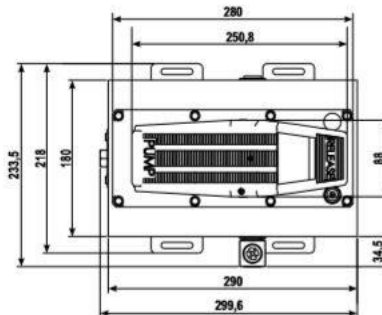
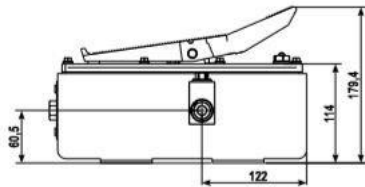

To order:

- P/N 913201640 HP1000 1000BAR BELL
- P/N 913200010 HP700 700BAR 1,4L BELL
- P/N 913200060 HP500 500BAR BELL
- P/N 913202190 HP350 350BAR BELL
- P/N 913200020 HP250 250BAR BELL

Accessories:

- Pedal protection kit
- Oversized tanks SL / XL
- Delivery valve straight fitting
- Hose Flex
- In line hand valve for double acting cylinders

Diagrammi consumo aria (l/min) - (air consumption):

Air Consume HP700

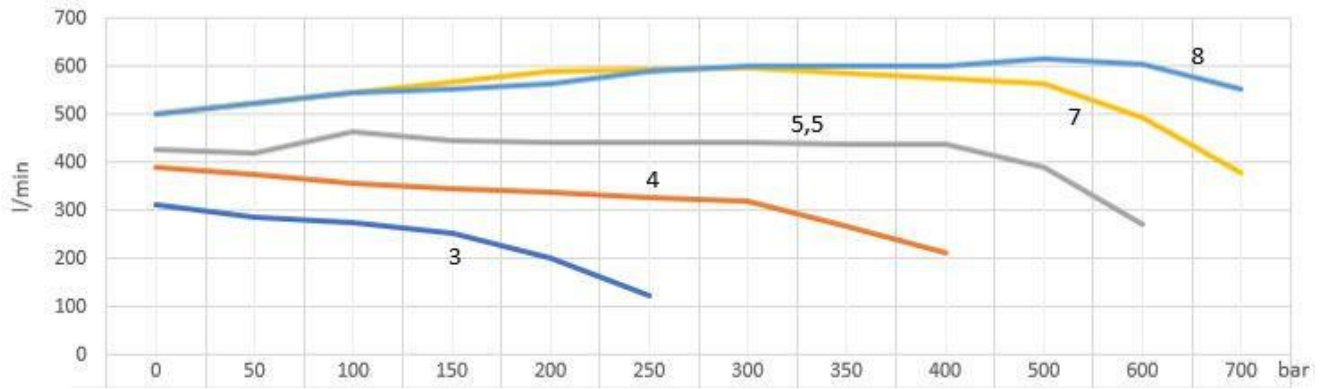

Air Consume HP500

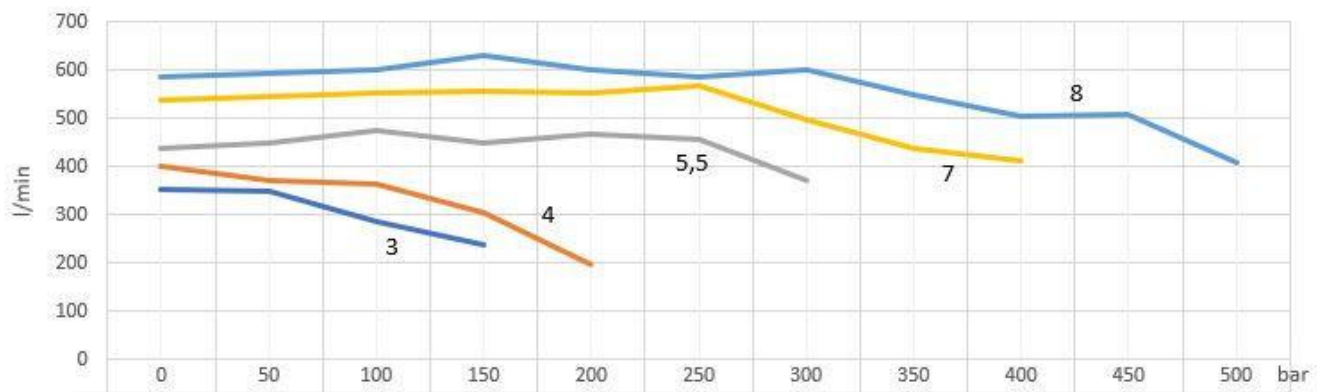

Air Consume HP250

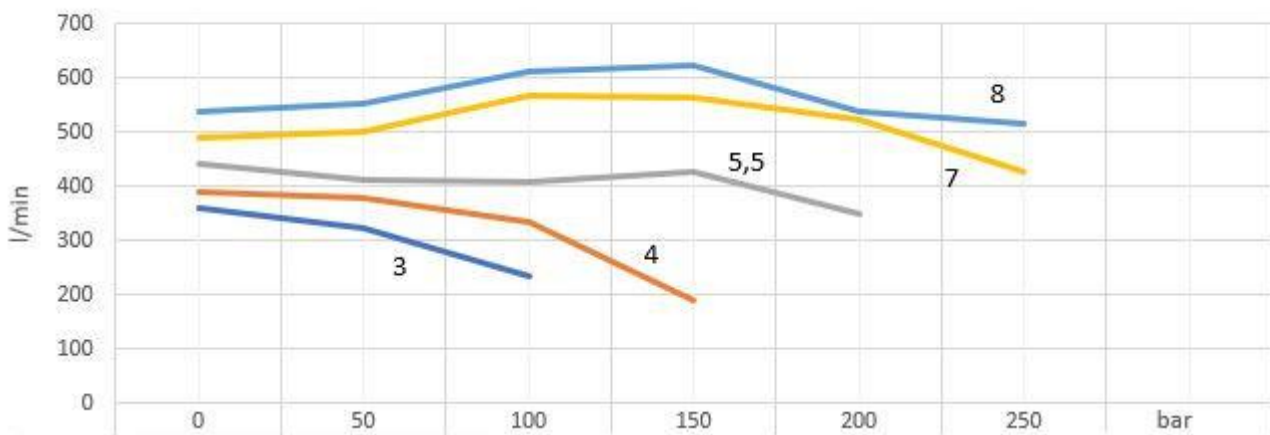

Diagrammi portata (l/min) - (oil flow):

HP 700 - Oil Flow Diagram

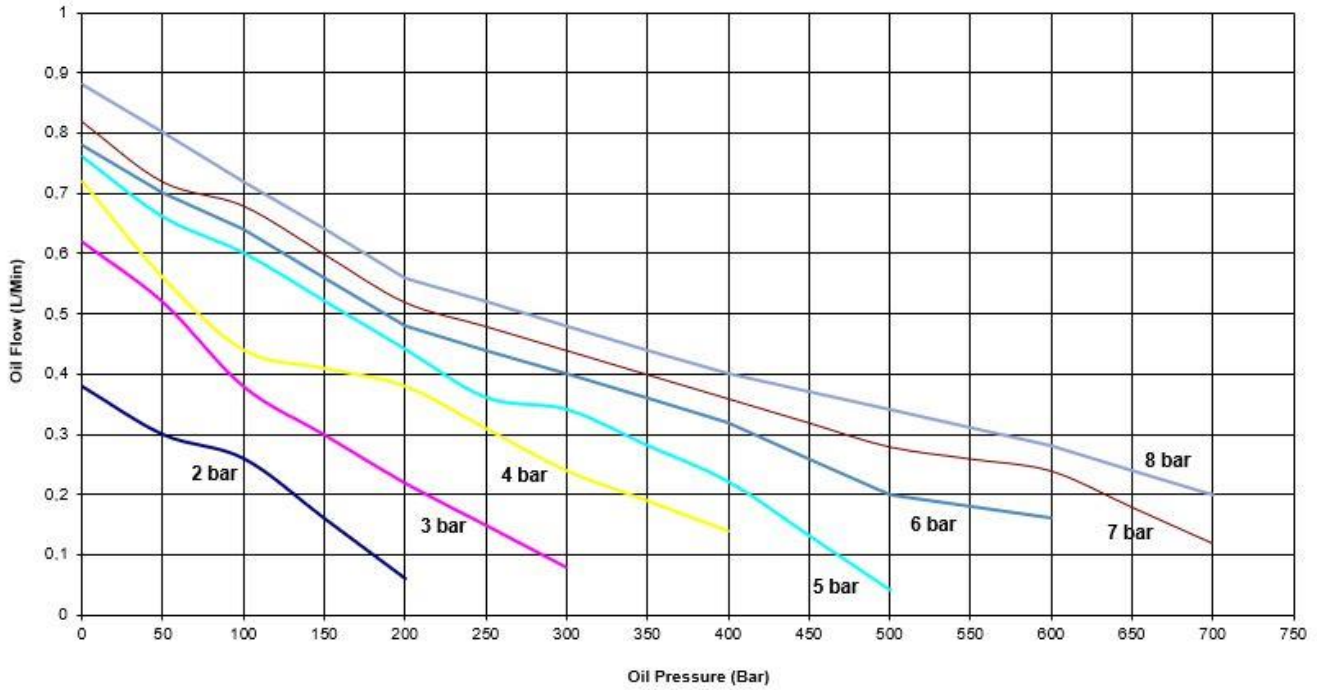

HP500

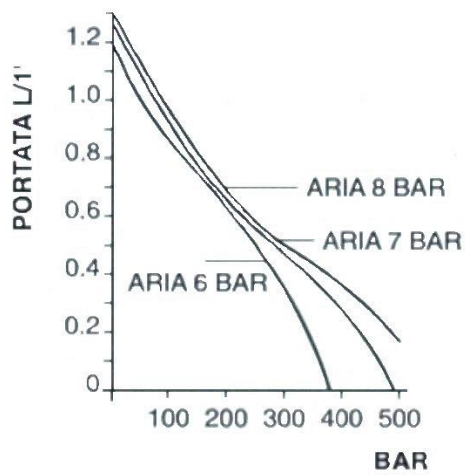

HP250

