



KITS



PUMPS



METERS



METERED NOZZLES



NOZZLES



WASTE OIL EQUIPMENTS

# DEPUROIL

## FEATURES

- IDEAL FOR DIALYSIS OF OIL
- COMPACTNESS
- SILENT
- CLOGGING INDICATOR
- **5 METERS OF CABLE**
- SPIRAL TUBES

The PIUSI DEPUROIL is an immediate mobile filtering unit, the easiest solution to a single step filtration suitable for any kind of tank. It includes the PIUSI VISCOMAT VANE pump, suitable for low/medium viscosity lubricants.

### PERFORMANCE

**AC**  
VOLTAGE  
POWER



DEPUROIL

### PACKAGING

WEIGHT		PACKAGING			
KG	LBS	MM	INCH	PCS/PALLET	PCS/BOX
28	61,7	600X290X300	23,6X11,4X11,8		1
28	61,7	600X290X300	23,6X11,4X11,8		1



FILTRATION



FLUID MONITORING



TANK MONITORING



HOSE REELS



ACCESSORIES



MERCHANDISE

INDEX



AIR



ANTIFREEZE



AdBlue®



BIODIESEL



DIESEL



FOOD



GASOLINE



GREASE



KEROSENE



OIL



WATER



WINDSCREEN

## CHART

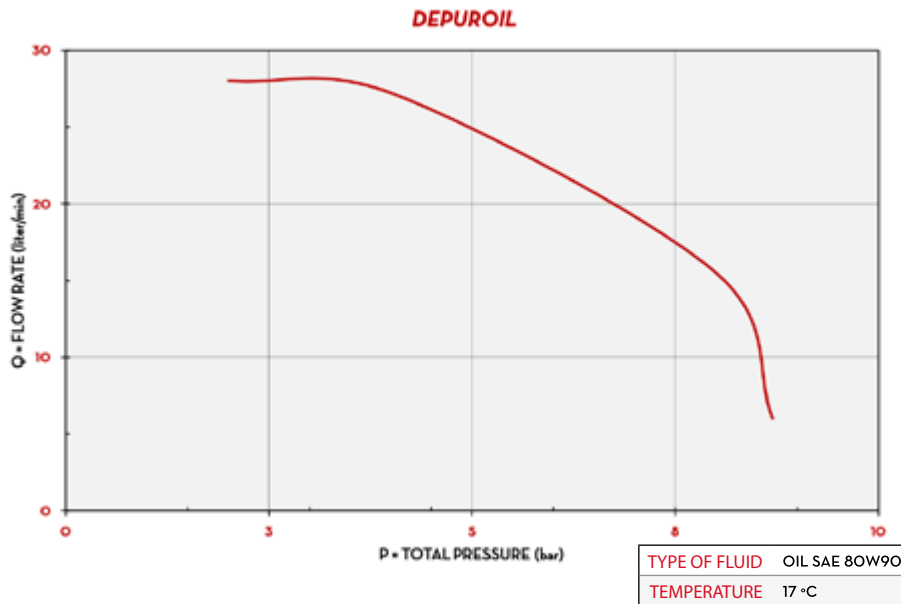

## IN THE BOX

- DEPUROIL
- FILTER CARTRIDGE
- SUCTION HOSE
- DELIVERY HOSE
- INSTRUCTION MANUAL

## DETAILS



LARGE DIAMETER WHEELS



STURDY STRUCTURE

## DIMENSIONS

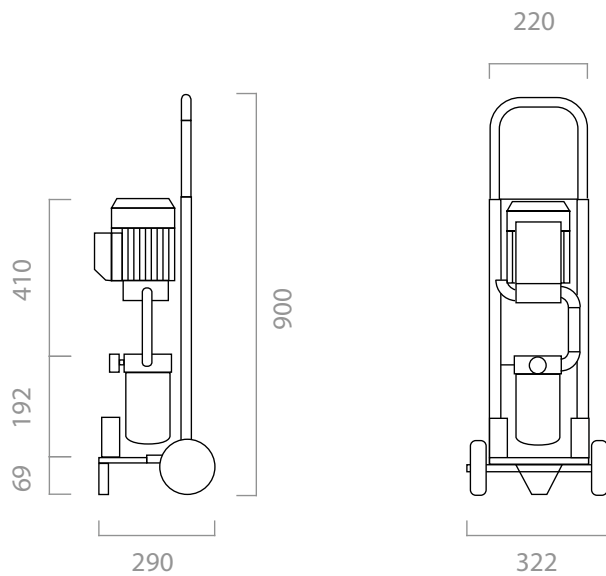

Dimensions expressed in millimeters

## MATERIALS

- BODY: CAST IRON
- ROTOR: SINTHERED STEEL
- VAINS: TECHNOPOLYMER
- SHAFT: STEEL
- FILTER: ABSORBENT FILTERING PAPER

## TECHNICAL DATA

DESCRIPTION	FLUIDS TYPE	FLOW RATE		VOLTAGE			PUMP TYPE	HOSE LENGHT		FILTERING CAPACITY MU
		L/MIN	GPM	AC V/HZ DC VOLT	POWER WATT	AMP. MAX.		DELIVERY /FT	SUCTION M/FT	
DEPUROIL M 230V/50HZ		20-25	5,28-6,6	230/50	1350	6,2	VISCOMAT 70	2 / 6,5	2 / 6,5	10
DEPUROIL 60		50	13	230/50	1350	6,2	VISCOMAT 90	2	2	10