

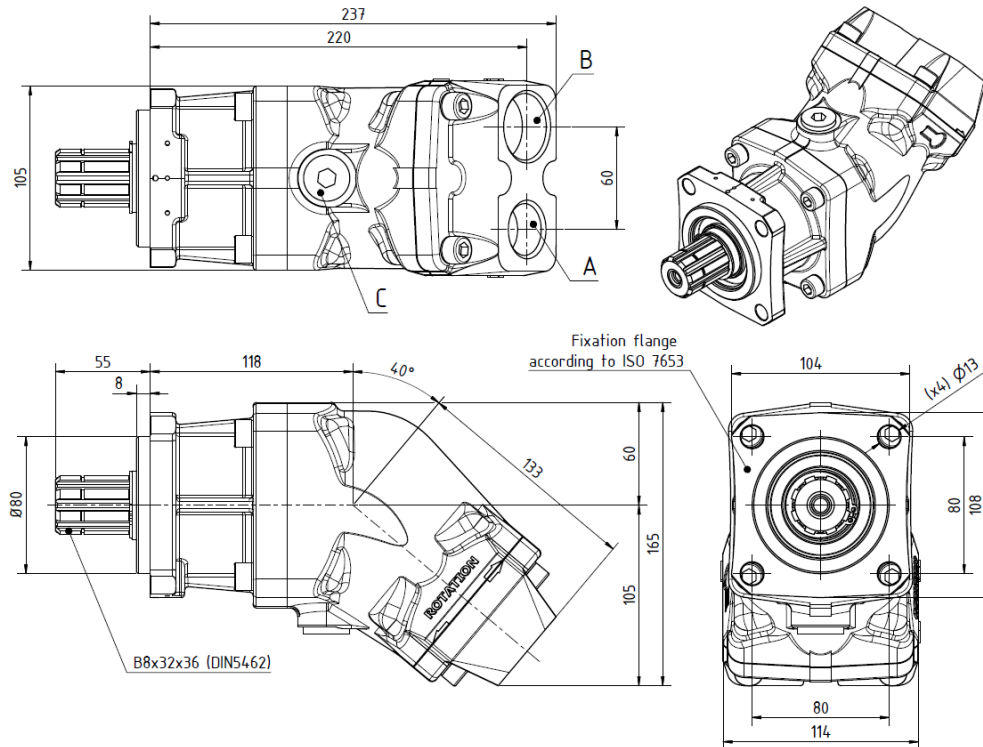

# OIL-HYDRAULIC PISTON PUMP IRON CAST BENT AXIS PUMP

Ref. BIF M

## Main Dimensions



(Dimensions in mm)

Main Data	
<b>Pumps BIF</b>	<b>50M</b>
<b>Displacement (cm<sup>3</sup>/rot.)</b>	50
<b>Operating pressure (bar) (up to)</b>	400
<b>Peak pressure (bar)</b>	450
<b>Operating rotation<sup>1</sup> (rpm)</b>	2300
<b>Max. rotation without load<sup>1</sup> (rpm)</b>	3000
<b>Weight (approx.) (kg)</b>	12.3
<b>Pistons quantity</b>	
<b>A-Oil outlet (DIN ISO 228)</b>	3/4" BSP
<b>B-Oil inlet (DIN ISO 228)</b>	1" BSP
<b>C</b>	Drain hole

### How to order:

**Example:** Pump 50cm<sup>3</sup>/rot; operating pressure up to 400 bar; peak pressure 450 bar, ref. BIF M BIF50M

<b>Fluids</b>	mineral oils type ISO HM or DIN 51524-2 HLP
<b>Recommended viscosity range</b>	20 to 40 cSt (mm <sup>2</sup> /s) at working temperature
<b>Limits viscosity range</b>	10 to 750 cSt (mm <sup>2</sup> /s)
<b>Start-up viscosity range, without load</b>	750 to 1500 cSt (mm <sup>2</sup> /s)
<b>Filtration</b>	10µm ISO4406 18/13
<b>Inlet pressure range</b>	0,7 to 2 bar abs
In the application of any of these pumps; the use of these data does not exempt the reading of the instruction "BI pumps recommendations before start-up"	



# OIL-HYDRAULIC PISTON PUMP IRON CAST BENT AXIS PUMP

Ref. BIF M

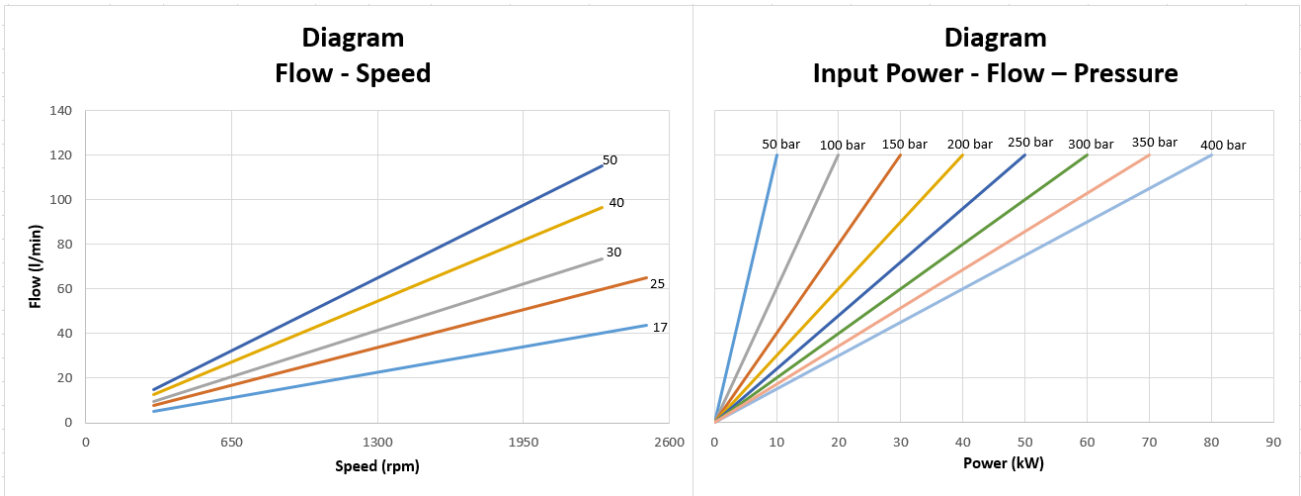

## Hose dimensions

Inlet Hose	
Flow (l/min)	Internal pipe diameter (inch)
20-30	1"1/4
30-40	1"1/4
50-60	1"1/2
70-90	1"3/4
100-120	2"

Outlet Hose					
Flow (l/min)	Internal pipe diameter (inch)				
	50-100	100-150	150-200	200-300	300-350
20	1/2"	1/2"	1/2"	1/2"	1/2"
30	1/2"	1/2"	1/2"	1/2"	1/2"
40	5/8"	1/2"	1/2"	1/2"	1/2"
50	5/8"	5/8"	5/8"	1/2"	1/2"
60	3/4"	5/8"	5/8"	5/8"	5/8"
70	1"	3/4"	3/4"	5/8"	5/8"
80	1"	3/4"	3/4"	3/4"	3/4"
90	1"	1"	1"	3/4"	3/4"
100	1"	1"	1"	1"	3/4"
110	1"	1"	1"	1"	1"
	50-100	100-150	150-200	200-300	300-350
	<b>P (bar)</b>				

### Important notes:

- To install one of these pumps, please consult and respect the instruction "BI pumps recommendations before start-up";
- Other axis available, please consult "Axel options".