



Type VEP two pump "high-low" unloading valves

- Single acting
- "High-low pressure"

Technical specifications and diagrams are measured with mineral oil of 46 cSt viscosity at 40°C (104°F) temperature.

Line	VEP 38	VEP 12	VEP 34	VEP 100	VEP 114	
Nominal flow	Ap (high pressure inlet port)	10 l/min (2.6 US gpm)	20 l/min (5.3 US gpm)	30 l/min (7.9 US gpm)	50 l/min (13.2 US gpm)	80 l/min (21.1 US gpm)
	Bp (low pressure inlet port)	25 l/min (6.6 US gpm)	45 l/min (11.9 US gpm)	80 l/min (21.1 US gpm)	150 l/min (39.6 US gpm)	200 l/min (52.8 US gpm)
	U (work port)	30 l/min (7.9 US gpm)	55 l/min (14.5 US gpm)	100 l/min (26.4 US gpm)	180 l/min (47.6 US gpm)	250 l/min (66 US gpm)
Max. pressure	Aluminium body = 210 bar (3050 psi) Steel body = 350 bar (5100 psi)					
Fluid	mineral based oil					
Viscosity	from 10 to 200 cSt					
Max. level of contamination	18/16/13 ISO4406					
Fluid temperature	with NBR seals from -20°C (-4°F) to 80°C (176°F)					
Environmental temp. for working conditions	from -40°C (-40°F) to 100°C (212°F)					
Weight	<i>aluminium</i>	1.20 kg (2.64 lb)	2.05 kg (4.52 lb)	3.70 kg (8.16 lb)	5.92 kg (13.05 lb)	11.67 kg (25.72 lb)
	<i>steel</i>	2.63 kg (5.80 lb)	4.50 kg (9.92 lb)	9.37 kg (20.66 lb)	14.48 kg (31.92 lb)	19.50 kg (42.99 lb)

NOTE - For different conditions, please contact Walvoil Sales Dpt.

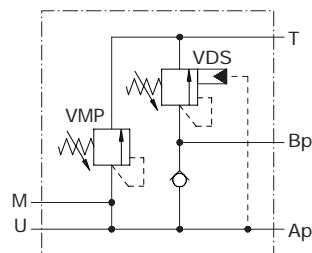

Dimensions

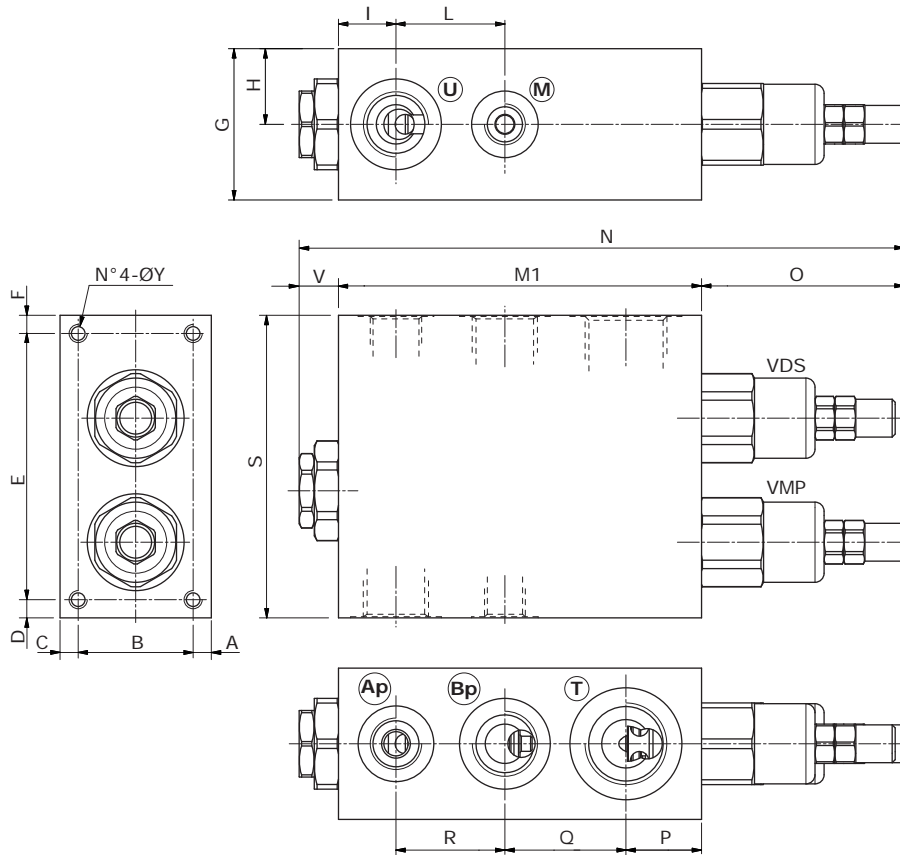

Valve type	U	M	T	Ap	Bp	Valve type	U	M	T	Ap	Bp
VEP 38	G3/8	G1/4	G1/2	G1/4	G3/8	VEP 38/SAE	SAE8	SAE6	SAE10	SAE6	SAE8
VEP 12	G1/2	G1/4	G3/4	G3/8	G1/2	VEP 12/SAE	SAE10	SAE6	SAE12	SAE8	SAE10
VEP 34	G3/4	G1/4	G1"	G1/2	G3/4	VEP 34/SAE	SAE12	SAE6	SAE16	SAE10	SAE12
VEP 100	G1"	G1/4	G1"1/4	G3/4	G1"	VEP 100/SAE	SAE16	SAE6	SAE20	SAE12	SAE16
VEP 114	G1"1/4	G1/4	G1"1/2	G3/4	G1"1/4	VEP 114/SAE	SAE20	SAE6	SAE24	SAE12	SAE20

Dimensions are in mm-in

Valve type	A	B	C	D	E	F	G	H	I	L	M1	N	O	ØY	P	Q	R	S	V
VEP 38	6	28	6	6	78	6	40	20	17	28	98	168.5	60	M6	20	33	29	90	10.5
VEP 38/SAE	0.24	1.10	0.24	0.24	3.07	0.24	1.57	0.79	0.67	1.10	3.85	6.63	2.36		0.79	1.30	1.14	3.54	0.41
VEP 12	6	38	6	6	88	6	50	25	19	36	120	200	67	M6	25	40	36	100	13
VEP 12/SAE	0.24	1.50	0.24	0.24	3.46	0.24	1.97	0.98	0.75	1.42	4.72	7.87	2.64		0.98	1.57	1.42	3.94	0.51
VEP 34	8	44	8	8	114	8	60	30	30	40	150	243	76.5	M8	28	52	40	130	16.5
VEP 34/SAE	0.31	1.73	0.31	0.31	4.49	0.31	2.36	1.18	1.18	1.57	5.90	9.57	3.01		1.10	2.05	1.57	5.11	0.65
VEP 100	10	50	10	10	130	10	70	35	30	70	180	285	88.5	M6	32	60	58	150	16.5
VEP 100/SAE	0.39	1.97	0.39	0.39	5.11	0.39	2.75	1.38	1.18	2.75	7.09	11.22	3.48		1.26	2.36	2.28	5.90	0.65
VEP 114	10	60	10	10	160	10	80	40	40	80	200	304	88.5	M8	35	70	60	180	15.5
VEP 114/SAE	0.39	2.36	0.39	0.39	6.3	0.39	3.15	1.57	1.57	3.15	7.87	11.97	3.48		1.38	2.75	2.34	7.09	0.61

Logic valves

Two pump "hi-low" unloading-valves

Ordering codes and description composition

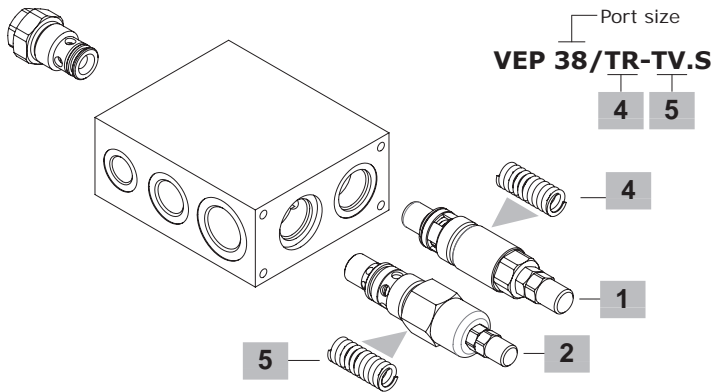

VEP complete valves

Single type valve configuration

High pressure (Ap): range 180-350 bar (2600-5075 psi) and standard setting 280 bar (4060 psi) at 5 l/min (1.32 US gpm); Low Pressure (Bp): see below

TYPE	CODE	DESCRIPTION
------	------	-------------

Configuration with G3/8 standard thread

VEP 38/TR-TV.S	1220021101	Aluminium body Bp: range 20-80 bar (290-1160 psi) - Standard setting 60 bar (870 psi) at 5l/min (1.32 US gpm)
-----------------------	------------	--

VEP 38/TR-TV.S/ac	1220022102	Steel body, as previous one
--------------------------	------------	-----------------------------

Configuration with G1/2 standard thread

VEP 12/TR-TV.S	1220031101	Aluminium body Bp: range 5-80 bar (72.5-1160 psi) - Standard setting 40 bar (580 psi) at 5l/min (1.32 US gpm)
-----------------------	------------	--

VEP 12/TR-TV.S/ac	1220032100	Steel body, as previous one
--------------------------	------------	-----------------------------

Configuration with G3/4 standard thread

VEP 34/TR-TV.S	1220041101	Aluminium body Bp: range 10-80 bar (145-1160 psi) - Standard setting 50 bar (725 psi) at 5 l/min (1.32 US gpm)
-----------------------	------------	---

VEP 34/TR-TV.S/ac	1220042100	Steel body, as previous one
--------------------------	------------	-----------------------------

Configuration with G1" standard thread

VEP 100/TR-TV.S	1220051101	Aluminium body Bp: range 20-80 bar (290-1160 psi) - Standard setting 60 bar (870 psi) at 5l/min (1.32 US gpm)
------------------------	------------	--

VEP 100/TR-TV.S/ac	1220052101	Steel body, as previous one
---------------------------	------------	-----------------------------

Configuration with G1"1/4 standard thread

VEP 114/TR-TV.S	1220061101	Aluminium body Bp: range 20-80 bar (290-1160 psi) - Standard setting 60 bar (870 psi) at 5l/min (1.32 US gpm)
------------------------	------------	--

VEP 114/TR-TV.S/ac	1220062100	Steel body, as previous one
---------------------------	------------	-----------------------------

Configuration with SAE8 standard thread

VEP 38/TR-TV.S/SAE	1220021200	Aluminium body Bp: range 20-80 bar (290-1160 psi) - Standard setting 60 bar (870 psi) at 5l/min (1.32 US gpm)
---------------------------	------------	--

Configuration with SAE10 standard thread

VEP 12/TR-TV.S/SAE	1220031101	Aluminium body Bp: range 5-80 bar (72.5-1160 psi) - Standard setting 40 bar (580 psi) at 5l/min (1.32 US gpm)
---------------------------	------------	--

Configuration with SAE12 standard thread

VEP 34/TR-TV.S/SAE	1220041200	Aluminium body Bp: range 10-80 bar (145-1160 psi) - Standard setting 50 bar (725 psi) at 5 l/min (1.32 US gpm)
---------------------------	------------	---

Configuration with SAE16 standard thread

VEP 100/TR-TV.S/SAE	1220051200	Aluminium body Bp: range 20-80 bar (290-1160 psi) - Standard setting 60 bar (870 psi) at 5l/min (1.32 US gpm)
----------------------------	------------	--

VEP complete valves (continue)

TYPE	CODE	DESCRIPTION
------	------	-------------

Configuration with SAE20 standard thread

VEP 114/TR-TV.S/SAE	1220061200	Aluminium body Bp: range 20-80 bar (290-1160 psi) - Standard setting 60 bar (870 psi) at 5l/min (1.32 US gpm)
----------------------------	------------	--

For other steel body configurations, other port sizes and configurations with FPM (Viton) seals, contact our Sales Dpt.

1 Direct acting pressure relief valve

Standard setting 160 bar at 5 l/min (2320 psi at 1.32 US gpm)

TYPE	CODE	DESCRIPTION
------	------	-------------

For G3/8 and SAE8 ports configuration

VMP 5/TR.S	1100520401	Setting range 50-220 bar (725-3200 psi) (Ap)
-------------------	------------	--

For G1/2, G3/4, SAE10 and SAE12 ports configuration

VMP 10/TR.S	1100530401	Setting range 50-220 bar (725-3200 psi) (Ap)
--------------------	------------	--

For G1", G1"1/4, SAE16 and SAE20 ports configuration

VMP 20/TR.S	1100540403	Setting range 50-220 bar (725-3200 psi) (Ap)
--------------------	------------	--

2 Sequence valve

Setting range 20-80 bar (290-1150 psi) (Lp)

Standard setting 160 bar at 5 l/min (2320 psi at 1.32 US gpm)

TYPE	CODE	DESCRIPTION
------	------	-------------

VDS/VEP 38/TV.S	1205020400	For G3/8 - SAE8 port configuration
------------------------	------------	------------------------------------

VDS/VEP 12/TV.S	1205030400	For G1/2 - SAE10 port configuration
------------------------	------------	-------------------------------------

VDS/VEP 34/TV.S	1205040405	For G3/4 - SAE12 port configuration
------------------------	------------	-------------------------------------

VDS/VEP 100/TV.S	1205050400	For G1" - SAE16 port configuration
-------------------------	------------	------------------------------------

VDS/VEP 114/TV.S	1205060400	For G1"1/4 - SAE20 port configuration
-------------------------	------------	---------------------------------------

3 Check valve

Opening pressure 0.5 bar (7.25 psi)

TYPE	CODE	DESCRIPTION
------	------	-------------

VUI 38/Pa0,5	1300020400	For G3/8 - SAE8 port configuration
---------------------	------------	------------------------------------

VUI 12/Pa0,5 pass.magg	1300030401	For G1/2 - SAE10 port configuration
-------------------------------	------------	-------------------------------------

VUI 34/Pa0,5 pass.magg	1300040401	For G3/4, G1", SAE12, SAE16 port config.
-------------------------------	------------	--

VUI 100/Pa0,5 pass.magg	1300050401	For G1"1/4, SAE20 port configuration
--------------------------------	------------	--------------------------------------

4 Pressure setting springs

TYPE	CODE	DESCRIPTION
------	------	-------------

For VMP 5 valve on VEP 38 complete valve (Ap)

TS	3MOL315330	Setting range 50-220 bar (725-3200 psi)
-----------	------------	---

TR	3ML1143600	Setting range 180-350 bar (2600-5100 psi)
-----------	------------	---

For VMP 10 valve on VEP 12 and VEP 34 complete valves (Ap)

TS	3MOL317420	Setting range 50-220 bar (725-3200 psi)
-----------	------------	---

TR	3MOL317440	Setting range 180-350 bar (2600-5100 psi)
-----------	------------	---

For VMP 20 valve on VEP 100 and 114 complete valves (Ap)

TS	3ML1204200	Setting range 50-220 bar (725-3200 psi)
-----------	------------	---

TR	3ML1214500	Setting range 180-350 bar (2600-5100 psi)
-----------	------------	---

5 Pressure setting springs

TYPE	CODE	DESCRIPTION
------	------	-------------

For VDS/VEP 38 valve on VEP 38 complete valve (Bp)

TB	3MOL314311	Setting range 5-40 bar (72.5-580 psi)
-----------	------------	---------------------------------------

TV	3MOL314330	Setting range 20-80 bar (290-1150 psi)
-----------	------------	--

For VDS/VEP 12 valve on VEP 12 complete valve (Bp)

TV	3MOL317420	Setting range 5-80 bar (72.5-1150 psi)
-----------	------------	--

For VDS/VEP 34 valve on VEP 34 complete valve (Bp)

TB	3ML1174500	Setting range 10-50 bar (145-725 psi)
-----------	------------	---------------------------------------

TV	3ML1204200	Setting range 10-80 bar (145-1150 psi)
-----------	------------	--

For VDS/VEP 100 valve on VEP 100 complete valve (Bp)

TB	3MOL314311	Setting range 5-40 bar (72.5-580 psi)
-----------	------------	---------------------------------------

TV	3MOL314330	Setting range 20-80 bar (290-1150 psi)
-----------	------------	--

For VDS/VEP 114 valve on VEP 114 complete valve (Bp)

TB	3MOL314311	Setting range 5-40 bar (72.5-580 psi)
-----------	------------	---------------------------------------

TV	3MOL314330	Setting range 20-80 bar (290-1150 psi)
-----------	------------	--

Rating diagrams

VEP 38 pressure drop vs. flow from Bp→T and Bp→U

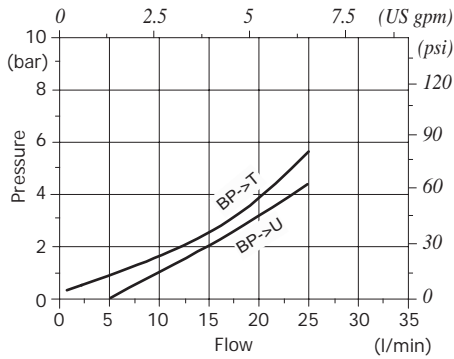

VEP 12 pressure drop vs. flow from BP→T and BP→U

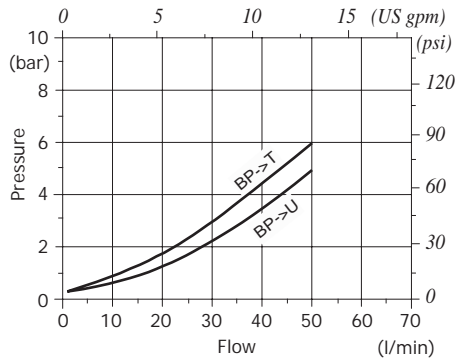

VEP 34 pressure drop vs. flow from Bp→T and Bp→U

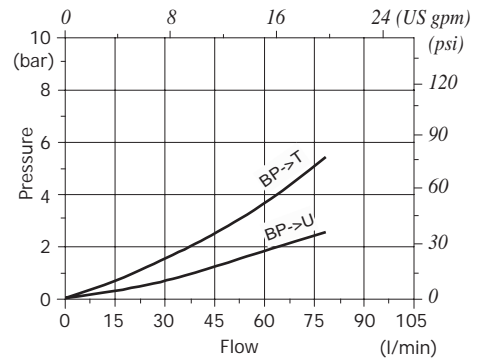

VEP 100 pressure drop vs. flow from Bp→T and Bp→U

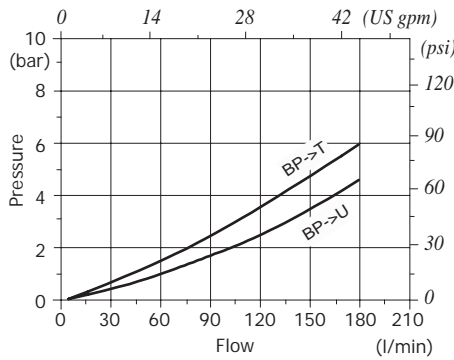

VEP 114 pressure drop vs. flow from Bp→T and Bp→U

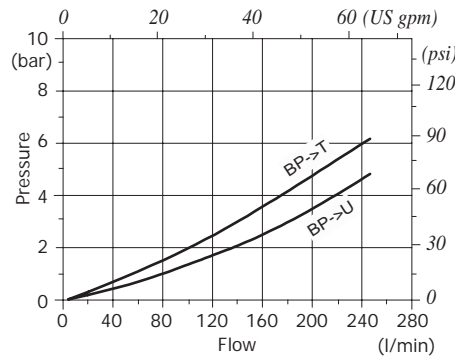

VEP 38: VMP setting example at 5 l/min (1.32 US gpm)

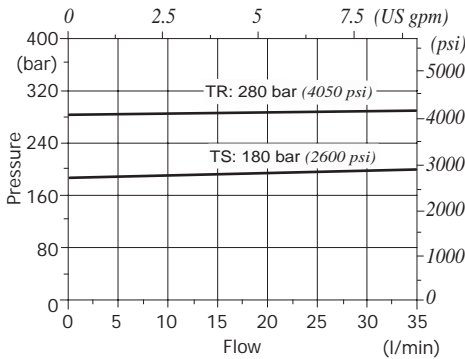

VEP 12: VMP setting example at 5 l/min (1.32 US gpm)

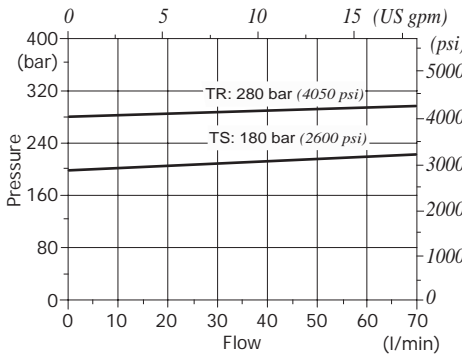

VEP 34: VMP setting example at 5 l/min (1.32 US gpm)

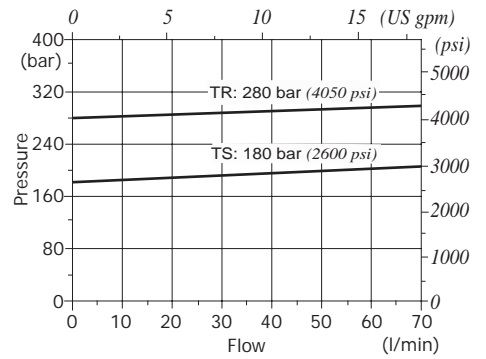

VEP 100: VMP setting example at 5 l/min (1.32 US gpm)

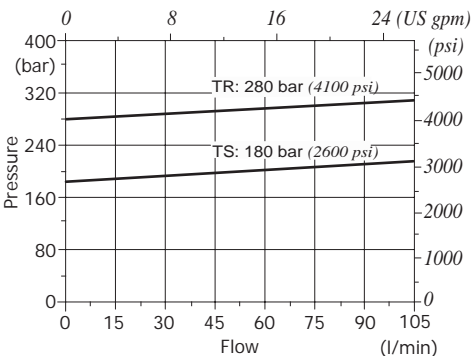

VEP 114: VMP setting example at 5 l/min (1.32 US gpm)

